

TRAILHEAD SERIES

MODERATE 44

Mod 44RTGO

Assembly Manual

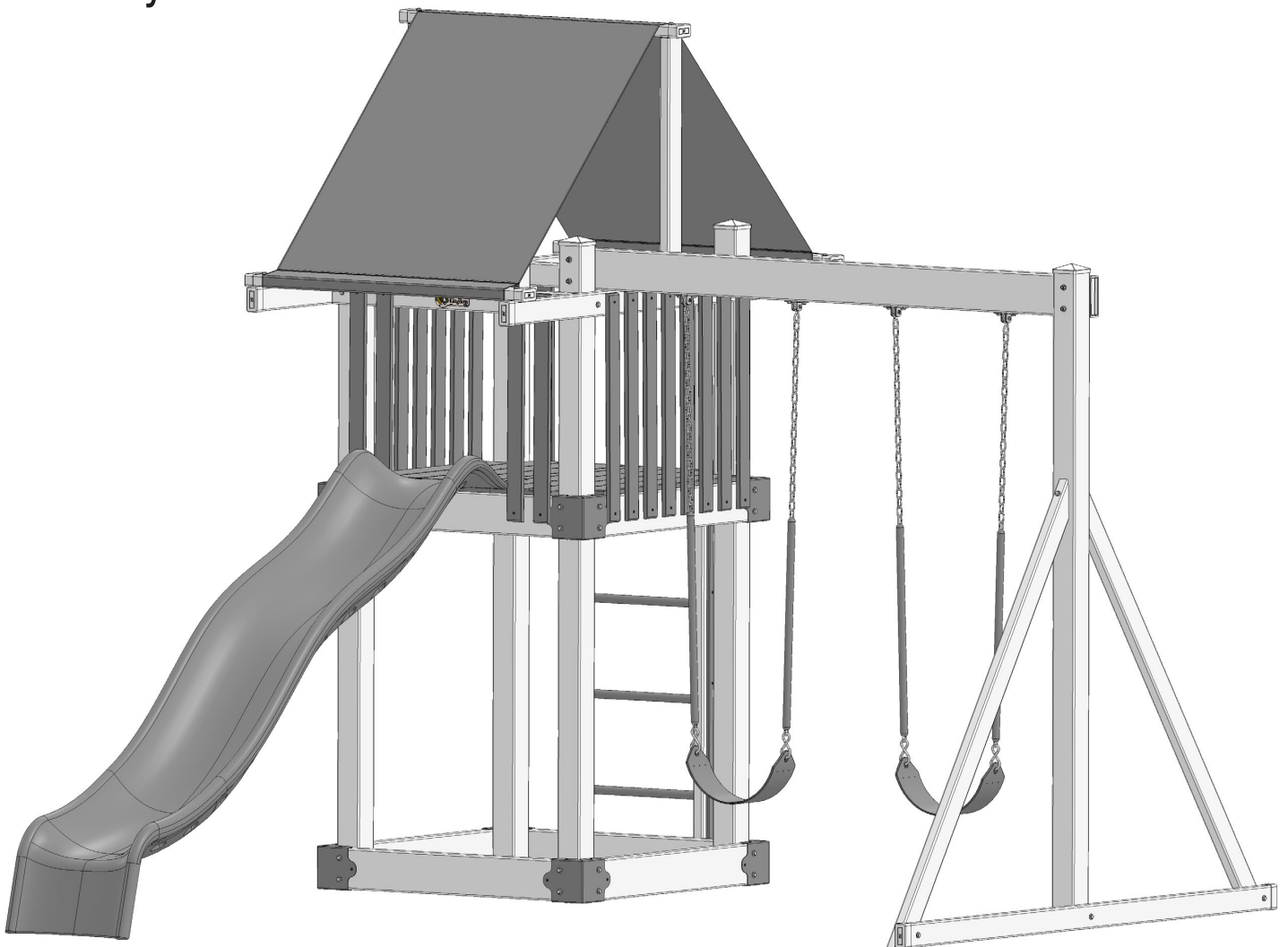

Recommended People: 2

Assembly Time: 2-3 hours



Swing Kingdom

www.swingkingdom.com

CONTENTS

Safety Info	4
Parts List	5
Part Drawings	6
Hardware	8
Tower Assembly.....	9
Floor Assembly	12
Railing Assembly.....	13
Poly Slat Assembly	13
Ladder Install.....	15
Swing Frame Assembly	15
Roof Assembly.....	16
Accessory Install	18
Stake Install.....	18

TOOLS INCLUDED FOR ASSEMBLY

- #2 Square Drive Bit
- Slat Spacer

TOOLS REQUIRED FOR ASSEMBLY

- Impact Drill
- Socket Attachment
- 1/2" Socket
- 9/16" Socket
- Step Ladder
- Tape Measure
- Safety Glasses
- Level
- 9/16" Wrench
- Hammer
- Knife or Box Cutter

ABOUT US

For loads of fun and family time, count on Swing Kingdom. A family operated manufacturer of premier vinyl playsets, we strive to design and build fine quality, affordable playsets perfect for children of all ages.

From the 500 square foot building where we started our business in 2000, to our current 43,000 square foot facility, Swing Kingdom has expanded to meet the growing demand for high quality, virtually maintenance-free playsets. We were the first manufacturer to combine vinyl PVC and structural wood, along with stainless steel hardware for superior strength. Today, we continue to use only the finest quality materials to ensure safe, durable playsets built to offer years of enjoyment.

Our playsets are loaded with activities that will spark every child's imagination and encourage daily physical activity and never-ending fun!

SUPPORT

Support@SwingKingdom.com

717-656-4449

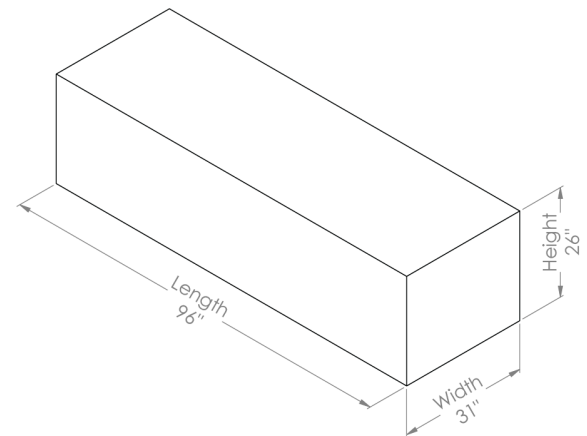

Skid Dimensions:
96" Length x 31" Width x 26" Height

Package Weight: 775 lbs

Version: 1.2
Last Updated: April 15, 2025

INTRODUCTION

Swing Kingdom's playsets are engineered from a safety first perspective. Our slip resistant vinyl-clad construction materials are always splinter free and no wood means no harsh chemical treatments. Stainless steel hardware brings added stability, while preventing rust and corrosion.

Our premium vinyl playsets are five times stronger than traditional wooden playsets. Each playset is manufactured with a high standard of durability and quality along with a 5-year warranty to stand behind our product.

We hope that the information on these pages will help you with assembling your Swing Kingdom playset. If you are unable to find the answers to your questions here when building, please contact your local authorized Swing Kingdom dealer, or call us direct at 717-656-4449.

WARRANTY

Subject to ordinary residential use and proper installation.

Swing Kingdom warrants to the original purchaser at the original installation address, that the structural components of the playset, such as the PVC vinyl and wood components are covered by a 5-year warranty. In addition, all canopies, slides, metal components, swings and accessories are warranted for 5 years from date of original purchase.

Swing Kingdom's products are not warranted as being suitable for a particular purpose. The suitability of the product is for the purchaser to determine. This warranty does not cover normal wear and tear, failure to properly maintain the product, or damage resulting from misuse or abuse of the product, additionally any acts of nature such as lightning, storms, hurricanes, tornadoes, earthquakes or any extreme weather conditions. Also any alteration, additions or relocation of the product will void this warranty.

Swing Kingdom reserves the right to examine photographs and/or physical evidence of the product claimed to be defective, and to recover product prior to any warranty claims. All products returned for inspection must be sent freight prepaid. In the event of a defect covered by these warranties, Swing Kingdom will remedy the defect within a reasonable time. The remedy will consist of repair or replacement of the defective piece unless it is not practical. Then Swing Kingdom will reimburse the original purchaser for the value of the defective piece.

All freight cost of replacement parts are not covered under warranty and will be the purchaser's responsibility to cover.

Adult supervision is recommended while enjoying your play system.



WARNING

- This instruction manual contains important information necessary for the proper assembly and safe use of the playset.
- Read and follow all warnings and instructions before assembling.
- Follow all warnings and instructions.
- Keep this manual for future reference.

SAFETY WARNING

Failure to follow these instructions could result in faulty equipment, which could cause property damage, personal injury or death! **Remember: Think Safety and Use Common Sense!**

Prevent Serious Injury or Death and Equipment Damage When Installing

- Work on dry sunny days to minimize the risk of slipping.
- Move items close to your body and use your legs when lifting an item from a low location.
- Avoid twisting, especially when bending forward while lifting. Turn by moving the feet rather than twisting the torso.
- Keep your elbows close to your body and keep the load as close to your body as possible.
- Limit weight you lift to no more than 50 pounds. When lifting product heavier than 50 pounds, use two or more people to lift the product up.
- Use personal protective equipment and clothing such as safety helmets, gloves, safety goggles, ear protection, and safety footwear.

Maintenance

It is of particular importance that these guidelines be followed at the beginning of each season as well as at regular intervals during the usage season:

- Check all nuts and bolts for tightness and tighten when required.
- Check all coverings for bolts and sharp edges and replace when required.
- Check swing seats, chains, ropes and other means of attachments for evidence of deterioration.
- Replace defective parts in accordance with the manufacturer's instructions.

General Safety Precautions

Users who use hand and power tools and who are exposed to the hazards of falling, flying, abrasive and splashing objects, or exposed to harmful dusts, fumes, mists, vapors, or gases must be provided with the particular personal equipment necessary to protect them from the hazard.

All hazards involved in the use of power tools can be prevented by following five basic safety rules:

- Keep all tools in good condition with regular maintenance.
- Use the right tool for the job.
- Examine each tool for damage before use.
- Operate according to the manufacturer's instructions.
- Provide and use the proper protective equipment.

Fasteners

When using power tools to apply fasteners, there are some precautions to consider:

- Fasteners must not be fired into material that would let them pass through to the other side.
- The fastener must not be driven into materials like brick or concrete any closer than 3 inches to an edge or corner.
- In steel, the fastener must not come any closer than one-half inch from a corner or edge.
- Fasteners must not be driven into very hard or brittle materials which might chip, splatter, or make the fastener ricochet.

Hardware Packs

Tower Hardware

- (40) 9/16" x 4" Lags
- (40) 3/8" Washers
- (24) 1 3/4" Washer Head Screws



Poly Slat Hardware

- (44) 1 3/4" Washer Head Screws



Ladder Hardware

- (6) 9/16" x 4" Lags
- (6) 3/8" Washers



Roof Hardware

- (6) 9/16" x 4" Lags
- (6) 3/8" Washers
- (4) 1/2" x 1 1/2" Lags
- (4) 5/16" Washers



Swing Frame Hardware

- (4) 9/16" x 6 1/2" Bolts
- (4) 9/16" Locking Nuts
- (3) 9/16" x 4" Lags
- (2) 9/16" x 3" Lags
- (13) 3/8" Washers



Floor Hardware

- (64) 2" Polybuster Screws



Slide Hardware

- (3) 1/4" x 1 1/4" Pan Head Screw
- (3) 5/16" Washers

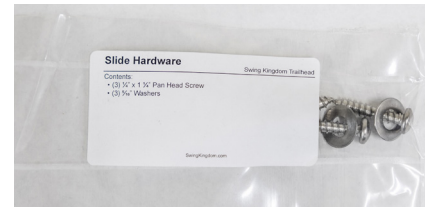

Playset Stakes

- (2) Stakes
- (2) 1/2" x 1 1/2" Lags
- (2) 5/16" Washers



PARTS LIST

Tower	
Parts	Quantity
96" 4x4 Post	4
48" 2x6	4
44" 2x6	4
43 3/4" 2x4 Floor Joist	2
43 3/4" 2x4 Railing	2
86" 2x4 Railing	2
5 1/2" x 47 3/4" Floorboard	6
2 5/8" x 47 3/4" Floorboard	1
5 1/2" x 35 3/4" Floorboard	2

Swing Frame	
94" 2x6 Swing Beam	1
96" 4x4 End Post	1
96" 2x4	1
80" 2x4 Brace	2

Roof	
Canvas Roof	1
50 1/2" 2x4	3
36" 2x4	2

Accessories	
Waterfall Slide	1
Ladder	1
Belt Swing	2
Poly Slat	22
Stake	2

Hardware Packs	
Tower Hardware	
Floor Hardware	
Poly Slat Hardware	
Roof Hardware	
Swing Frame Hardware	
Ladder Hardware	
Slide Hardware	

Tower Parts

A - 48" 2x6 (x4)

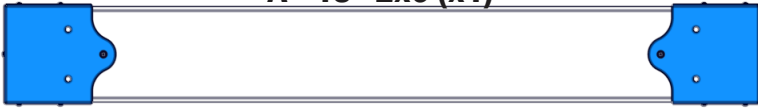

B1 & B2 - 44" 2x6 (x2)



C1 & C2 - 96" 4x4 Post (x4)



D1 & D2 - 44" 2x6 with Joist Hangers (x2)



E - 43 3/4" 2x4 Floor Joist (x2)



F1 - 2 5/8" x 47 3/4" Floorboard (x1)

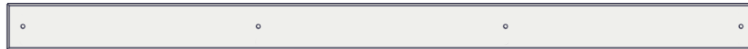

F2 - 5 1/2" x 47 3/4" Floorboard (x6)

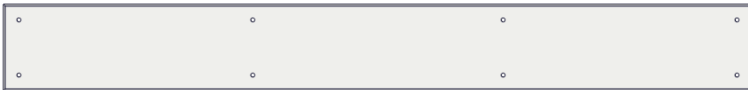

F3 - 5 1/2" x 35 3/4" Floorboard (x2)

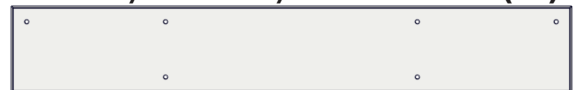

G1 - 43 3/4" 2x4 with Sequence Plaque (x1)



G2 - 43 3/4" 2x4 with Ladder Holes (x1)



H - 86" 2x4 Railing (x2)



I - 2 5/8" x 33 3/8" Poly Slat (x22)



J - Slat Template (x1)



Roof Parts

P1 - 50 1/2" 2x4 (x1)



O - 36" 2x4 (x2)

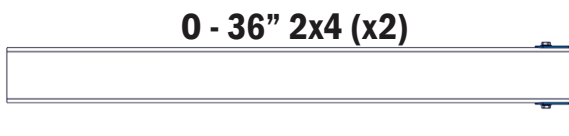

P2 - (1) 108" Canvas Roof with (2) 50 1/2" 2x4's (x1)

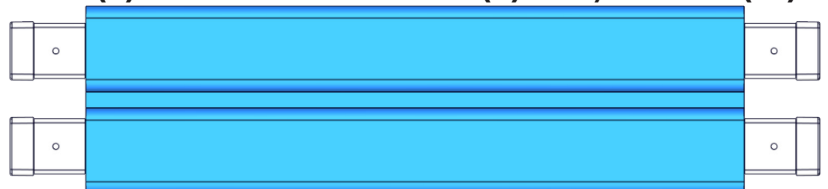

Swing Frame Parts

K - 96" 4x4 Post (x1)



L - 94" 2x6 Swing Beam (x1)



M - 96" 2x4 (x1)



N - 80" 2x4 Brace (x2)



Accessories

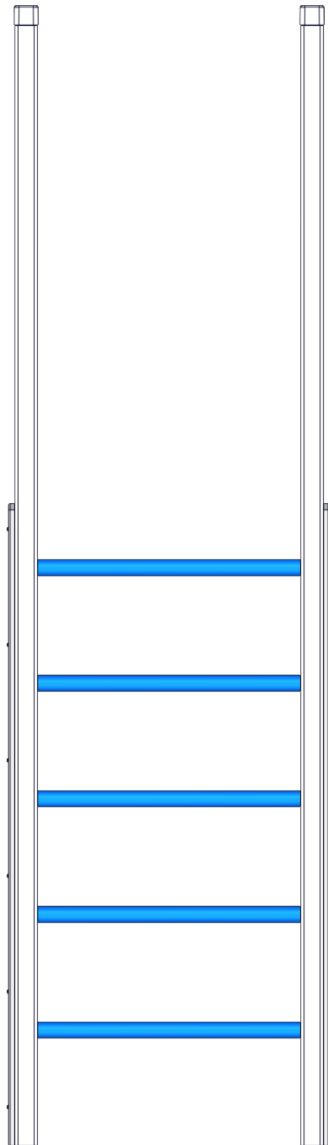

Ladder (x1)

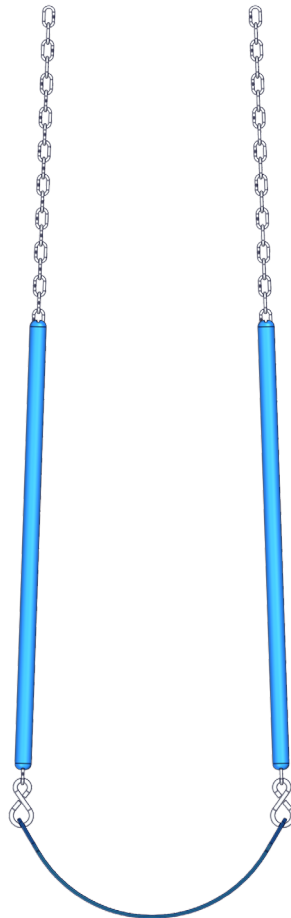

Belt Swing (x2)



Waterfall Slide (x1)

HARDWARE

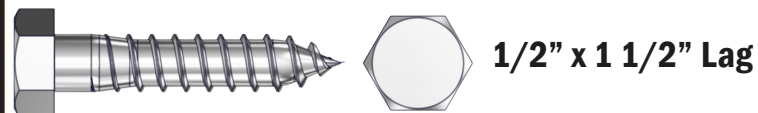
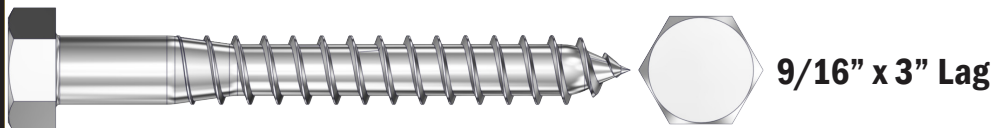
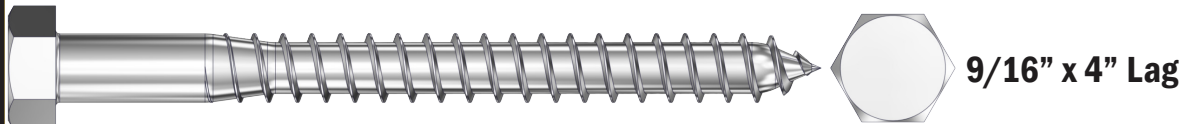

TOWER ASSEMBLY

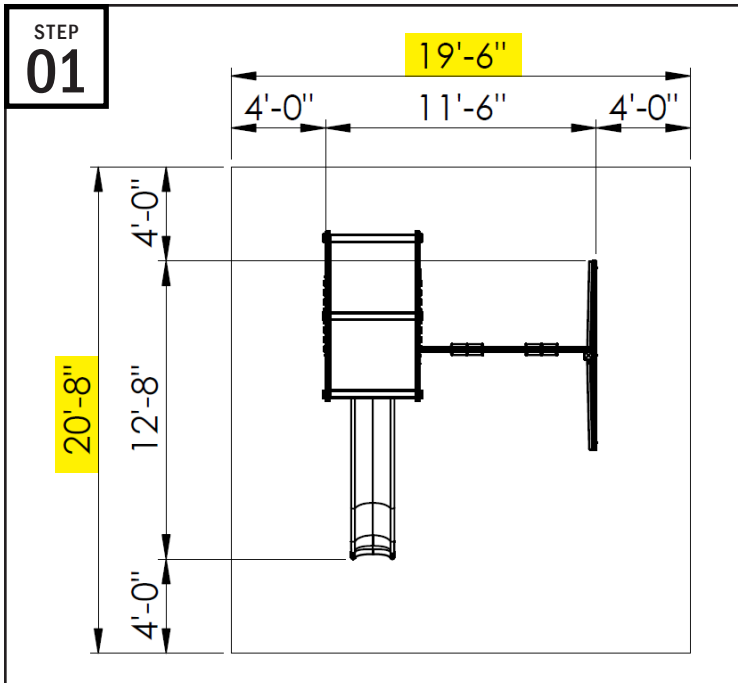

- **Review the dimensions above** (4ft is our recommended space around the playset. CPSC recommends 6ft. You may need to review your local laws or guidelines for more assistance.)
- **Find a level surface.** (You may need to dig out high areas or use treated lumber to block up low areas to make your surface level.)
- **Determine where you want the front & back of the playset.**
- **Lay out each bundle.** (Don't unwrap the bundles until you reach the appropriate step. Only cut in the creases to avoid damaging items.)

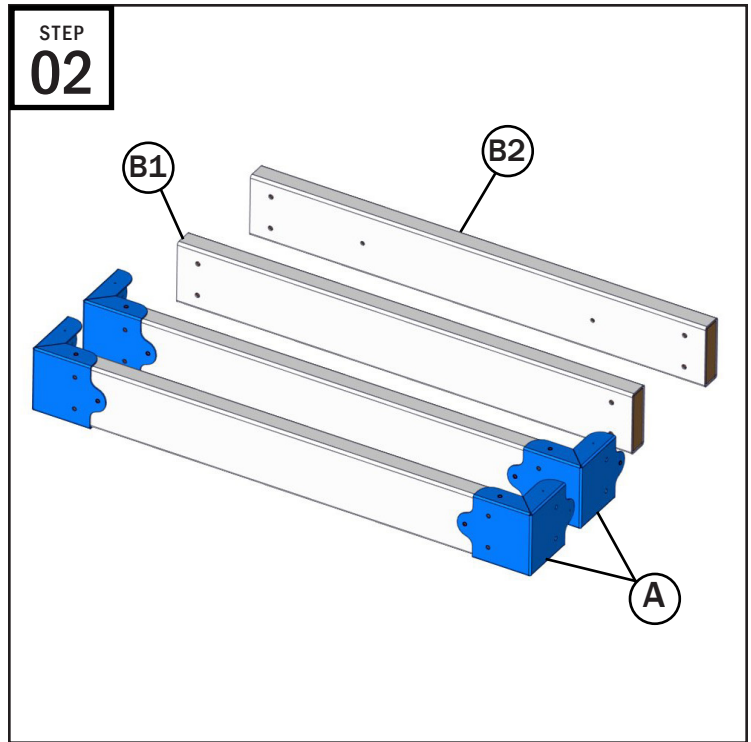

Locate and prepare the "Base Bundle" which includes...

- A: (2) 48" 2x6 with Corner Brackets
- B1: (1) 44" 2x6
- B2: (1) 44" 2x6 with Ladder Holes

Also locate the "Tower Hardware" bag to be used until step 12.

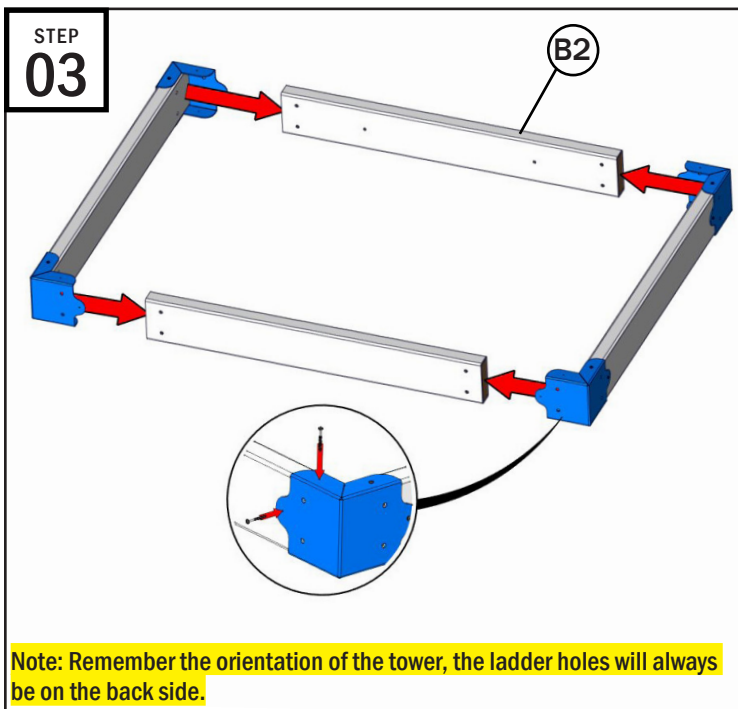

Note: Remember the orientation of the tower, the ladder holes will always be on the back side.

- Arrange the items so that all 2x6s fit inside the corner brackets.
- "B2" has the ladder holes, so it will be at the back of the swingset.
- Push the 2x6s into the corner brackets. The large holes in the corner brackets should line up with the holes in the 2x6.
- Using the #2 Drive Bit, fasten the bracket to the 2x6 with (2) Washer Head Screws into the small screw holes in the bracket.
- Repeat the last 2 steps on the remaining 3 corners.

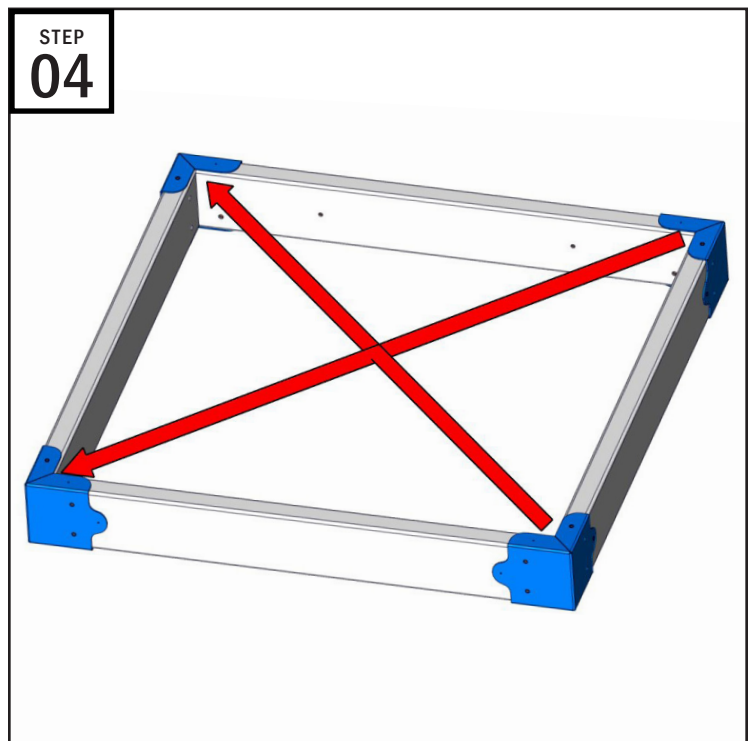

- To check if the base is square, measure from corner to corner, then measure the opposite corner to corner.
- If one corner measurement is larger than the other, then push in the corners with the larger measurement.
- Repeat until the base is as square as can be (The corner to corner measurements are equal.)

TOWER ASSEMBLY

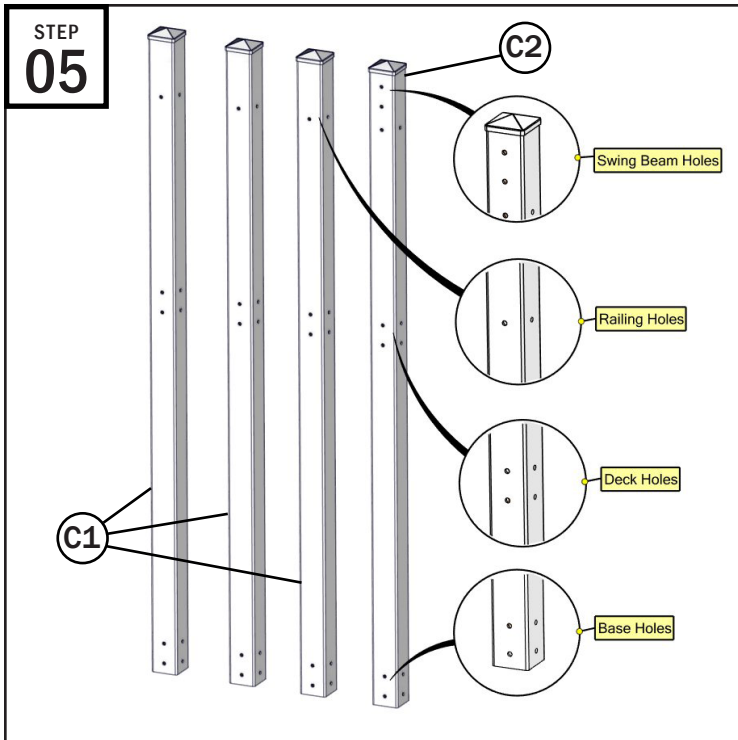

Locate the "Post Bundle 1 & 2" which includes...

- C1: (3) 96" 4x4 posts
- C2: (1) 96" 4x4 post with Swing Beam Holes

Note the holes shown above for later reference.

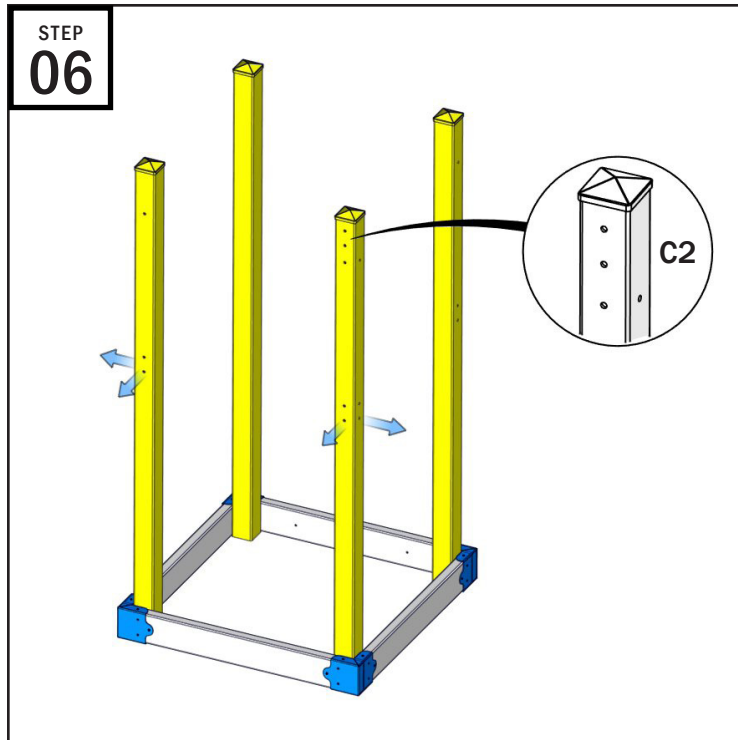

The 4x4 posts should be positioned with the following specifications.

- Each post will be oriented so the pre-drilled holes are facing outward.
- "C2" has extra holes for the swing beam and will need to be installed at the front right corner of the tower. The top 2 holes will face with the front and back of the playset.

You will need to place the posts 1 at a time.

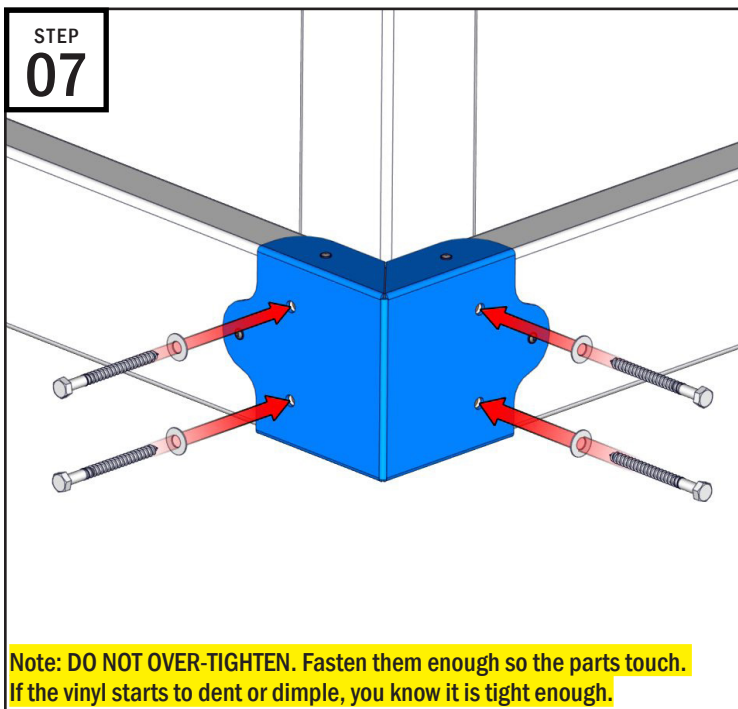

Note: DO NOT OVER-TIGHTEN. Fasten them enough so the parts touch. If the vinyl starts to dent or dimple, you know it is tight enough.

- Press the bottom of the 4x4 against the inside corner of the base.
- Fasten the 4x4 posts to the 2x6 using (4) 9/16" x 4" Lags & 3/8" Washers.
- Between fastening each Lag, use a level on the 4x4 post. You may need to push the post to get it level (It doesn't have to be perfect. The post will correct itself through future steps.)
- Repeat for the remaining 3 corners.

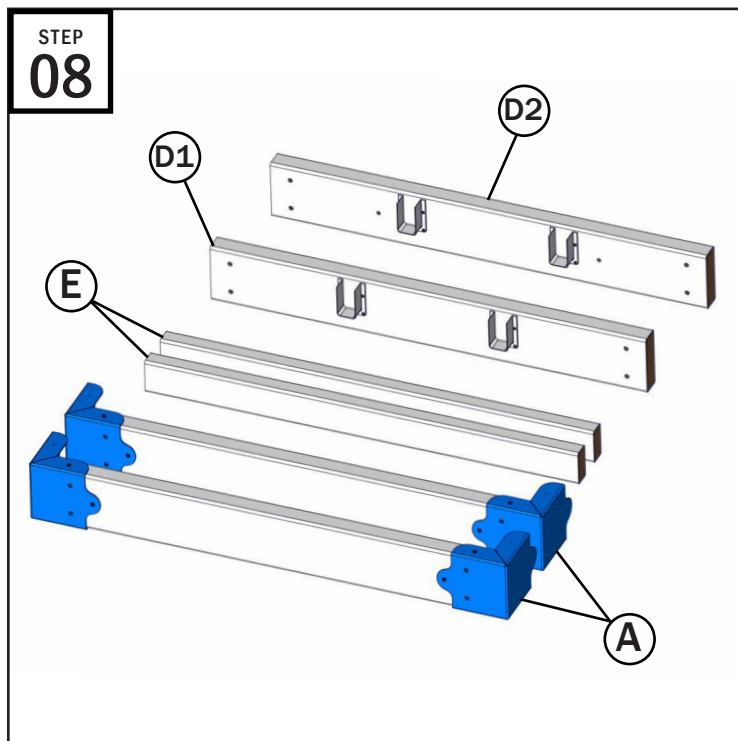

Locate and prepare the "Floor Bundle" which includes...

- A: (2) 48" 2x6 with Corner Brackets
- D1: (1) 44" 2x6 with Joist Hangers
- D2: (1) 44" 2x6 with Joist Hangers with Ladder Holes
- E: (2) 43 3/4" 2x4 Joists

TOWER ASSEMBLY

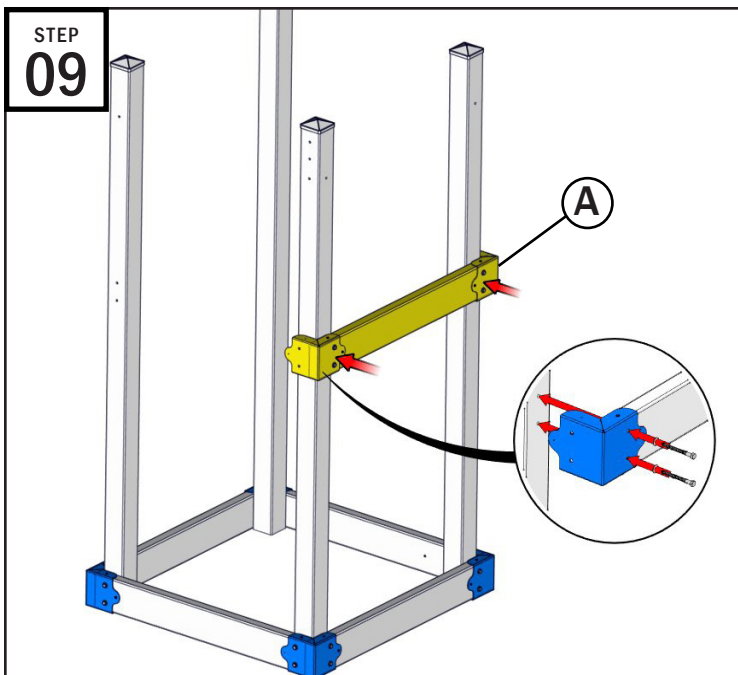

Note: DO NOT OVER-TIGHTEN. Fasten them enough so the parts touch. If the vinyl starts to dent or dimple, you know it is tight enough.

- Place one of the “A” items on one of the sides of the tower.
- Using (4) 9/16” x 4” Lags & 3/8” Washers, drill into the large holes of the 2x6 so that the tip of the lags are showing on the other side.
- Use the tip of the lags to find the holes on the 4x4 post.
- Fasten the Lags the into the 4x4 post.

Note: Do not fasten the side that doesn't have a 2x6 post in.

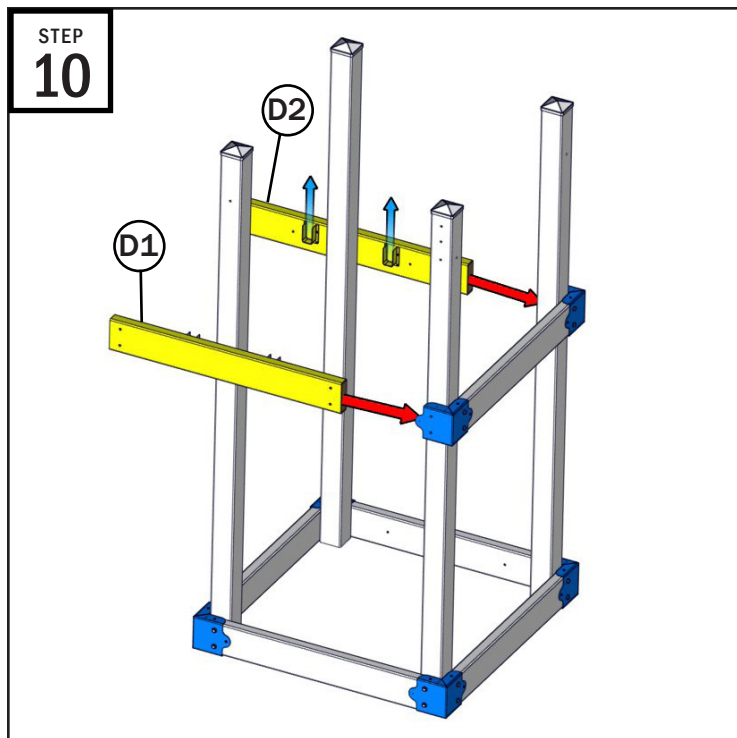

- Place “D1” & “D2” in the open ends of the corner brackets. “D2” has the ladder holes and needs to be placed in the back.
- Make sure the joist holders are on the inside of the tower with the joist openings are facing upwards.
- These should sit freely in the corner brackets, but you may need a 2nd person to hold them up for this step and step 11.

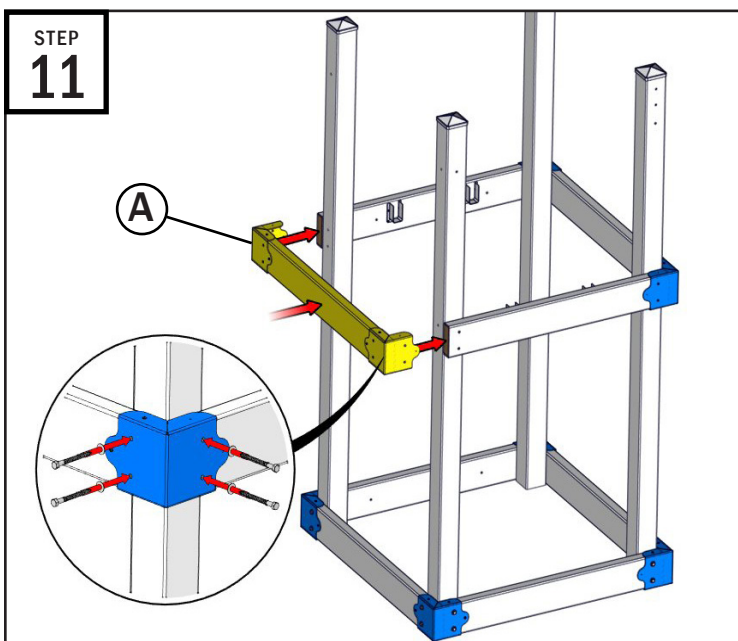

Note: DO NOT OVER-TIGHTEN. Fasten them enough so the parts touch. If the vinyl starts to dent or dimple, you know it is tight enough.

- Place the left over “A” on the remaining side of the tower, fitting the corner brackets over the 2x6.
- Using (4) 9/16” x 4” Lags & 3/8” Washers, repeat the same fastening and alignment tips from step 9 to fasten A to the 4x4 posts.
- Finish fastening the remaining sides to the 4x4 posts.

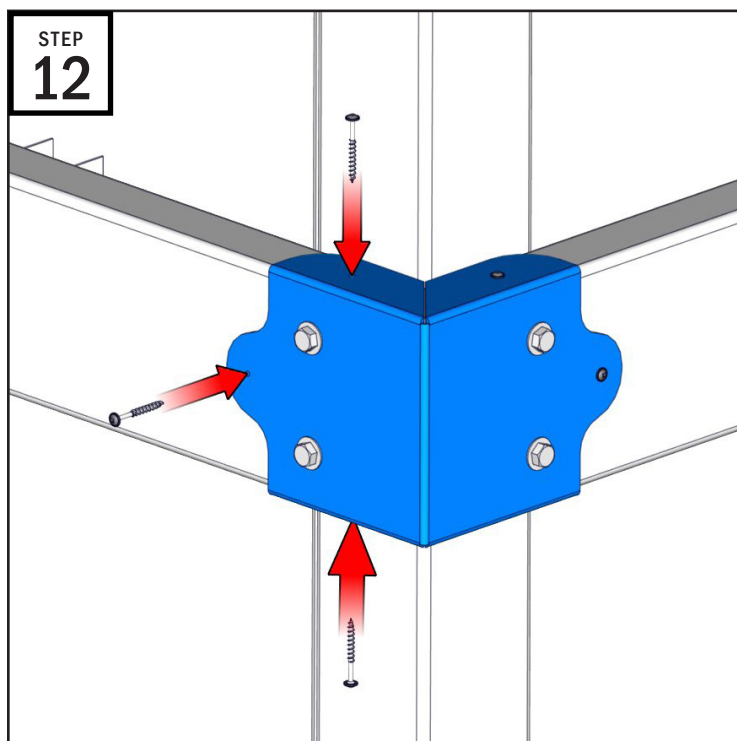

- Using the #2 Drive Bit, finish fastening the Brackets into the 2x6s with (3) Washer Head Screws (one side will already have screws).
- Repeat on the remaining 3 corners.

TOWER ASSEMBLY - FLOOR ASSEMBLY

STEP
13

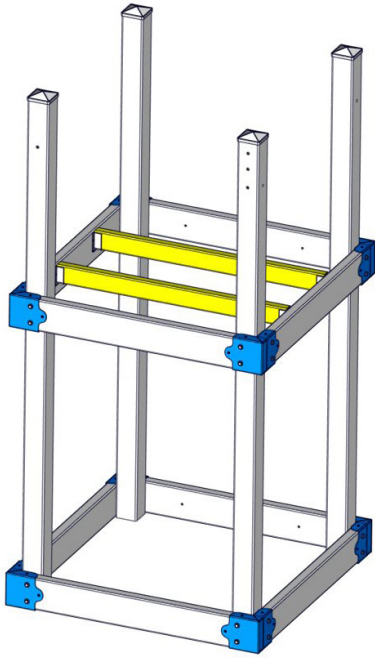

- You will have 2 joists remaining (E). Place these on the joist hangers.

You have now completed the main tower frame. The tower should look like the image above.

Continue to start the Floor Assembly

STEP
14

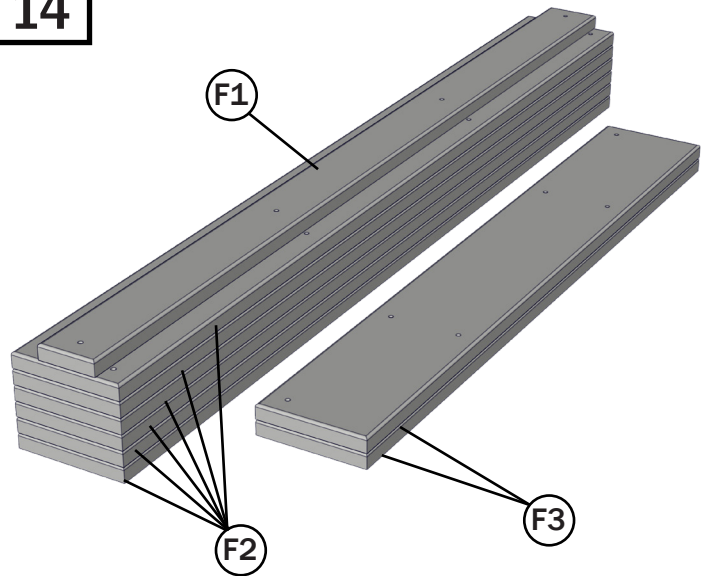

Locate and prepare the "Floorboard Bundle" which includes

- F1: (1) 2 5/8" x 47 3/4" Floorboard
- F2: (6) 5 1/2" x 47 3/4" Floorboards
- F3: (2) 5 1/2" x 35 3/4" Floorboards

Also locate the "Floor Hardware" bag.

STEP
15

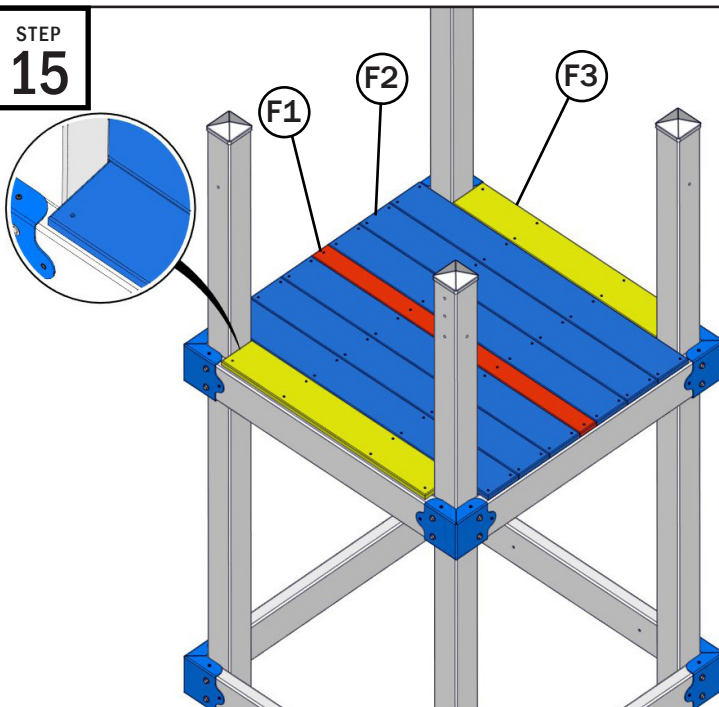

- Place the (6) "F2"s perpendicular from the joists below them.
- Place "F1" in the center of the tower.
- Place the (2) "F3"s on the sides. Make sure the corners with the pre-punched holes are facing outward.
- Center the floorboards. The boards are not 100% accurate. Run your fingers along both sides of the floorboards and adjust them one by one to make them as centered as possible.

STEP
16

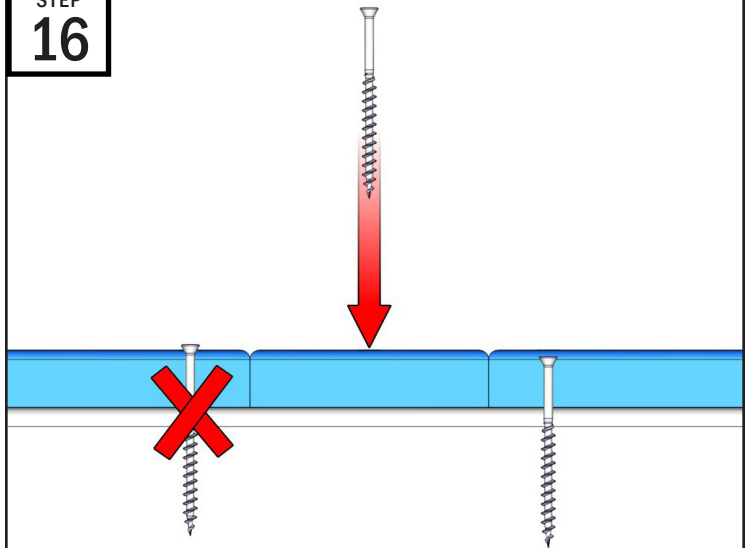

Note: Smaller screws like this can strip easily. Make sure your drill is aligned straight up and down with the screw. Stripping screws can damage the bit and cause more screw stripping.

- Center one of the corner "F2" boards and use the #2 Drive Bit to drill (1) Polybuster Screw into a pre-punched corner hole.
- Repeat with the neighboring "F2", adjusting to center all boards.
- Drill the remaining screws into the pre-punched holes. Each hole will line up with the joists and base boards underneath.

Note: Fasten the screws so the head of the screw is below the surface of the deck as shown above.

RAILING ASSEMBLY - POLY SLAT ASSEMBLY

STEP
17

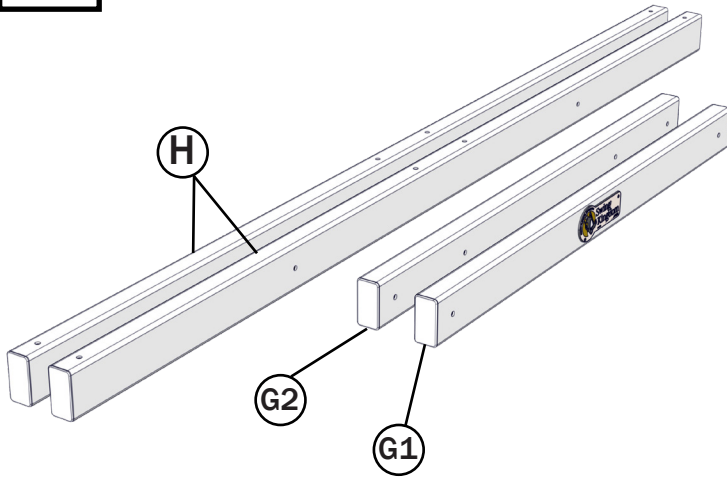

Locate the "Railing Bundle". This bundle will include:

- G1: (1) 43 3/4" 2x4 with Sequence Plaque
- G2: (1) 43 3/4" 2x4 with Ladder Holes
- H: (2) 86" 2x4

STEP
18

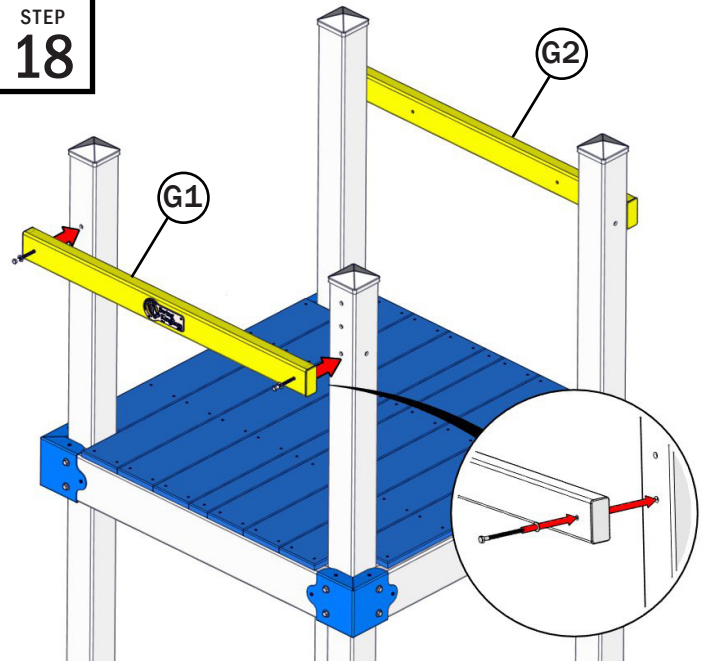

Note: DO NOT OVER-TIGHTEN. Fasten them enough so the parts touch. If the vinyl starts to dent or dimple, you know it is tight enough.

- Place "G1" on the front of the tower with the plaque facing outward. Align the holes with the 4x4 holes.
- Do the same with "G2", except on the back of the tower.
- Fasten both onto the 4x4 posts with (4) 9/16" Lags & 3/8" Washers (2 each side).

STEP
19

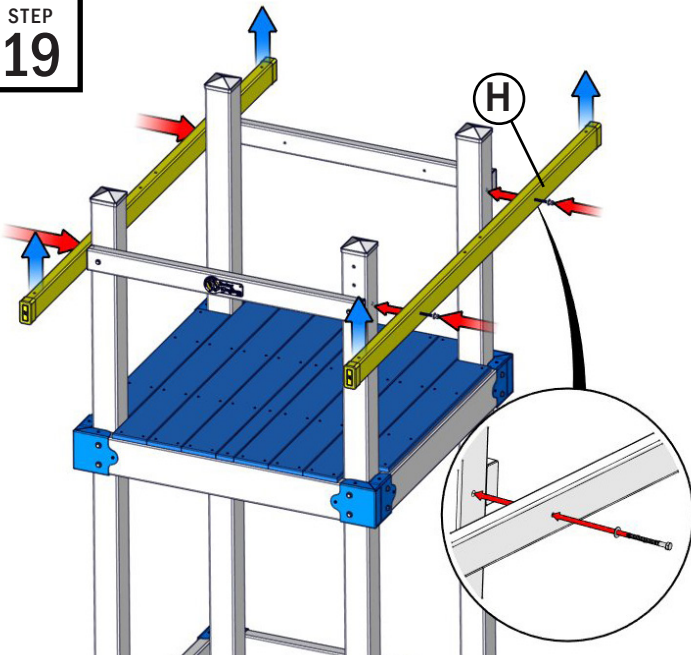

Note: DO NOT OVER-TIGHTEN. Fasten them enough so the parts touch. If the vinyl starts to dent or dimple, you know it is tight enough.

- Place the (2) "H"s on either side of the playset and align the pre-drilled holes.
- "H" have 4 extra holes on one side, these holes need to be facing up as shown by the blue arrows above.
- Fasten these using the same hardware from the previous step.

STEP
20

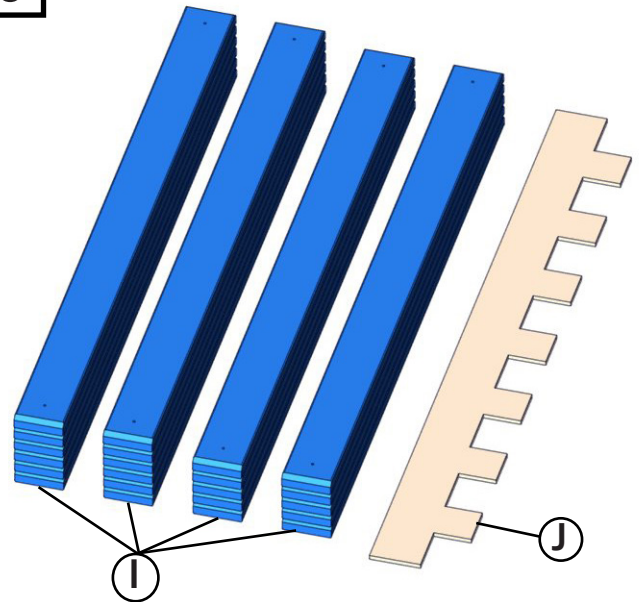

Locate the "Poly Slat Bundle". This bundle will include:

- I: (22) 3/4" x 2 5/8" x 33 3/8" Poly Slats
- J: (1) Poly Slat Template

Also locate the "Poly Slats Hardware" bag.

POLY SLAT ASSEMBLY

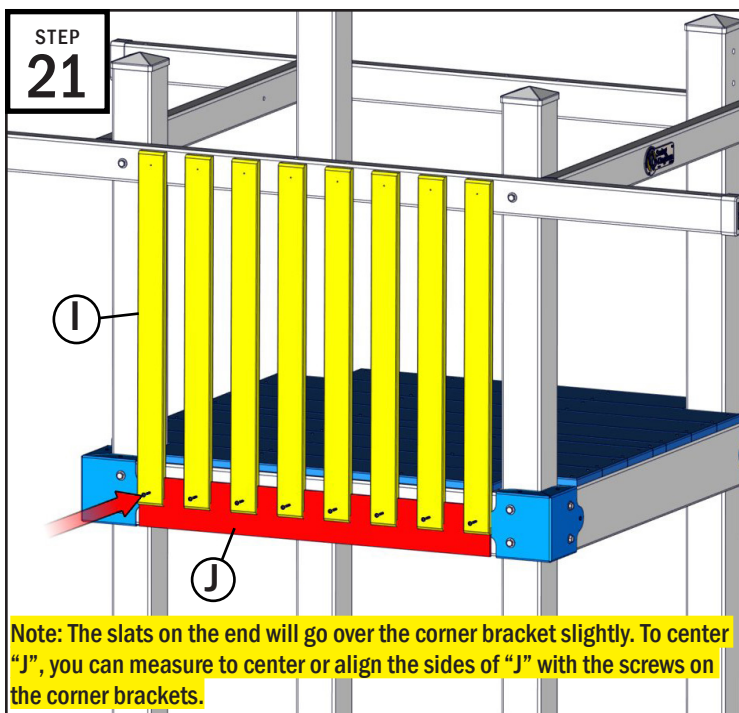

Note: The slats on the end will go over the corner bracket slightly. To center "J", you can measure to center or align the sides of "J" with the screws on the corner brackets.

- Use the #2 Square Drive Bit, drill 2" Washer Head Screws into "I" just enough so it is not or is barely protruding through the other side.
- On the side of the tower, place "J", aligning the bottom flush with the bottom of the 2x6 board and center on the board (see note above). Have a 2nd person hold "J" or use a clamp.
- One at a time, place "I" in the groove of "J" and fasten the bottom screws into the 2x6.

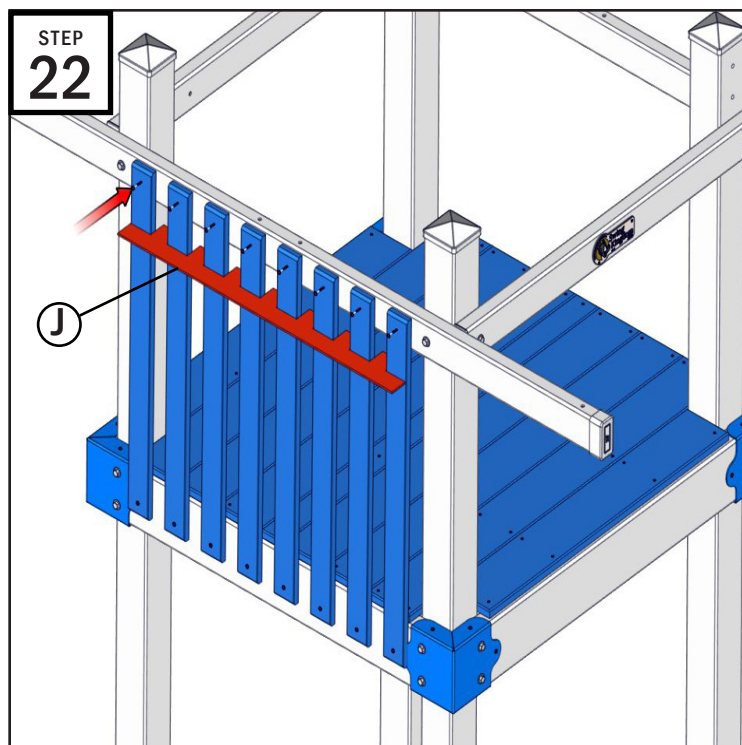

- Place "J" at the top of the slats holding them against the 2x4 railing.
- Use a level on the first slat to get it aligned correctly. "J" will align the rest of the slats.
- Fasten the top slats with the same hardware in the previous step.

Note: 8 slats with 2 screws per slat are used on this side.

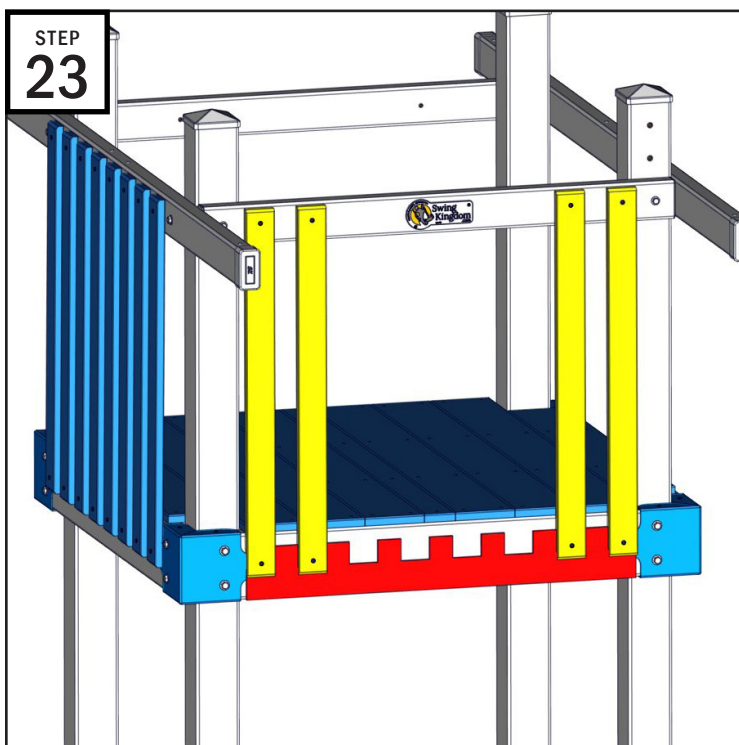

- Repeat the same slat and spacer process on the front.

Note: Only use 4 slats (2 on each end) on the front to leave access to the slide.

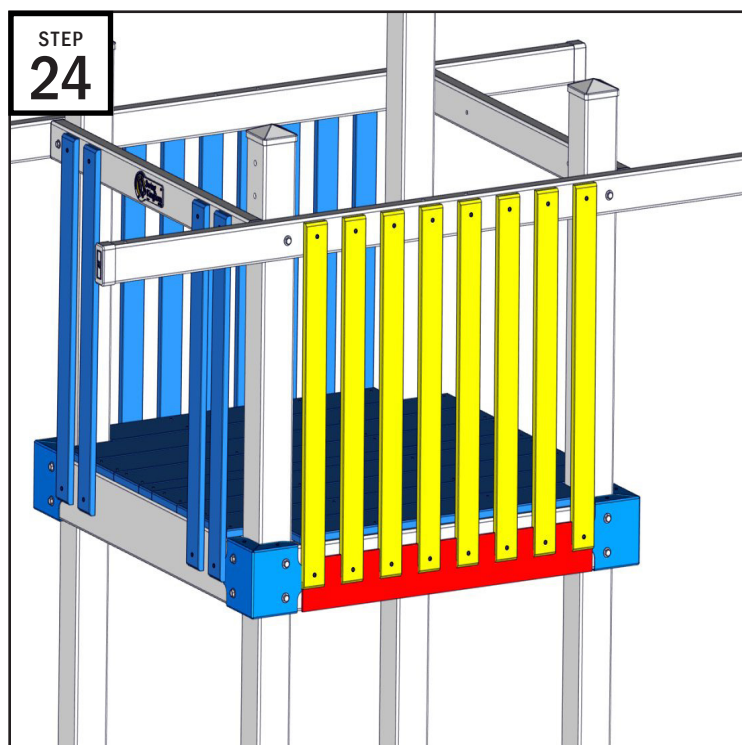

- Repeat the same slat and spacer process on the other tower side.

Note: Both sides of the tower will use 8 slats per side leaving no large gaps.

LADDER ASSEMBLY - SWING FRAME ASSEMBLY

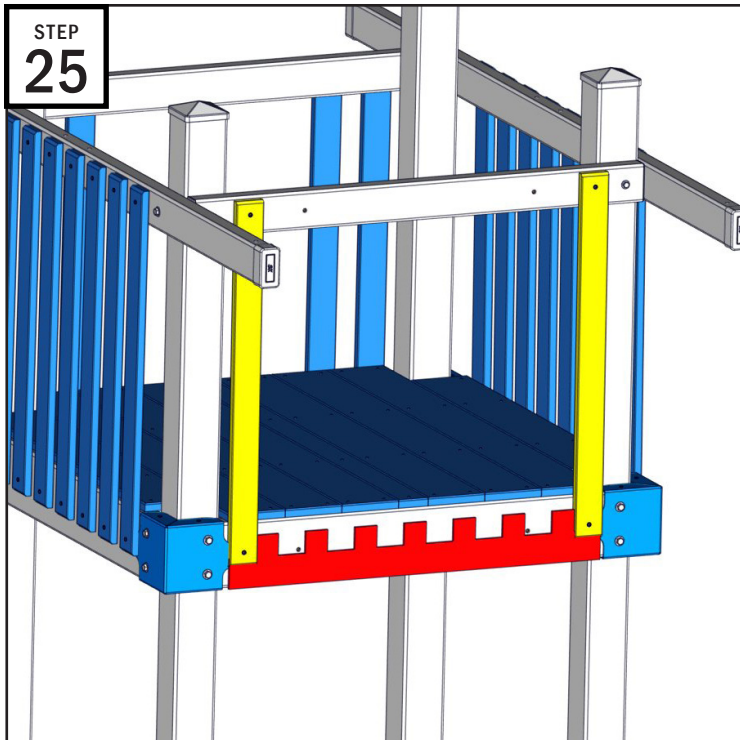

STEP
25

- Repeat the same slat and spacer process on the back.
- Note: Only use 2 slats (1 on each end) on the back to leave access to the ladder.

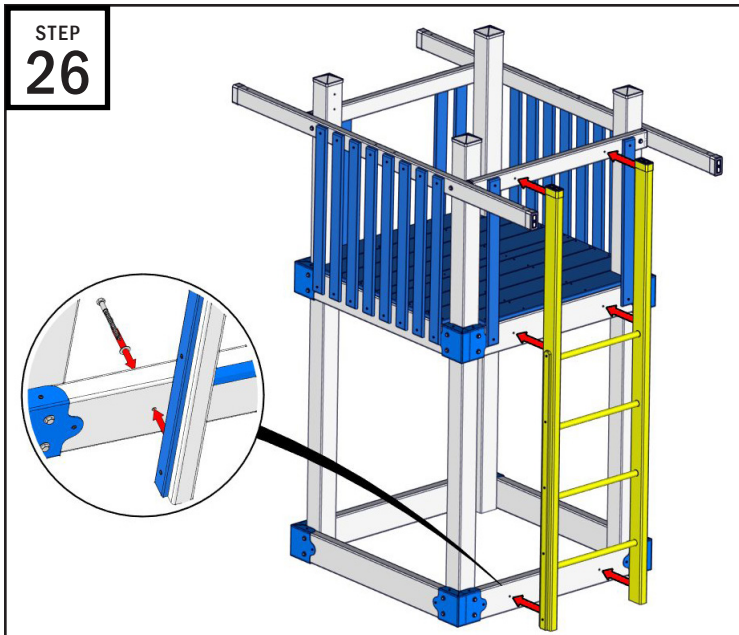

STEP
26

Note: DO NOT OVER-TIGHTEN. Fasten them enough so the parts touch. If the vinyl starts to dent or dimple, you know it is tight enough.

- Locate the Ladder and the "Ladder Hardware" bag.
 - Place the Ladder on the back side of the tower.
 - The Ladder will have pre-drilled holes on one side. The holes will face the inside of the tower.
 - Fasten the Ladder to the tower using (6) 9/16" x 4" Lags & 3/8" Washers through the pre-drilled holes in the 2x6's.
- Note: You will drill the Lags from the inside of the tower.

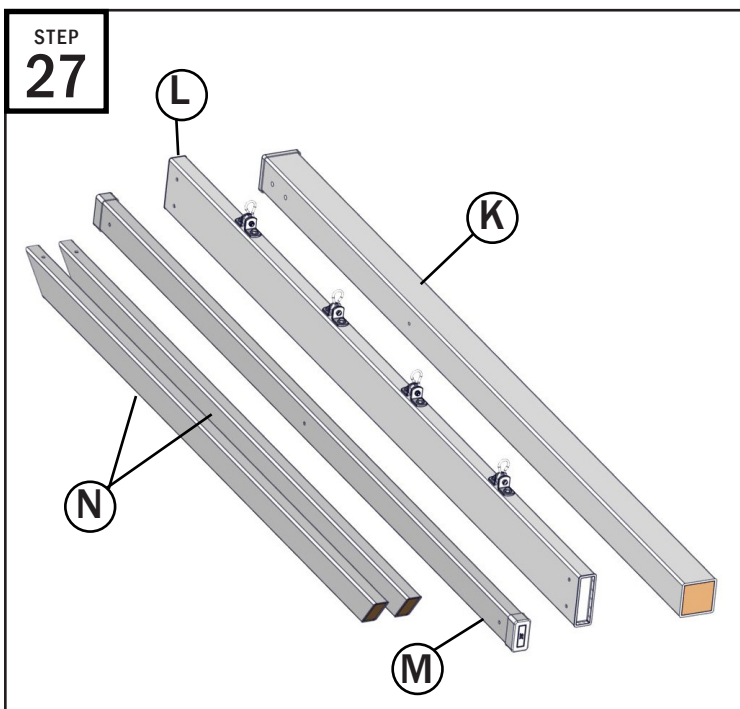

STEP
27

- Locate the "Swing Frame Bundle", which will include:
- K: (1) 96" 4x4 Post
 - L: (1) 94" 2x6 Swing Beam
 - M: (1) 96" 2x4
 - N: (2) 80" 2x4 Brace

Also locate the "Swing Frame Hardware" bag.

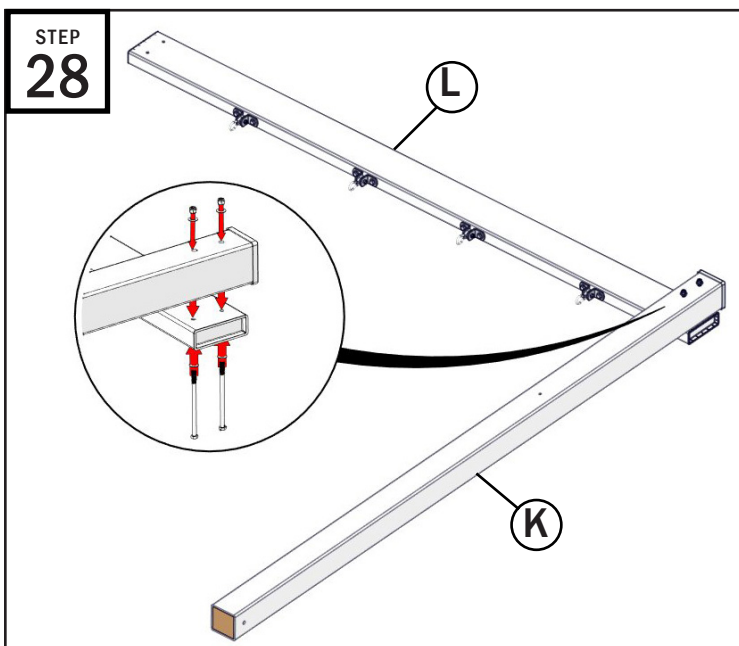

STEP
28

Note: DO NOT OVER-TIGHTEN. Fasten them enough so the parts touch. If the vinyl starts to dent or dimple, you know it is tight enough.

- Place "K" & "L" together as shown. (Swing hooks on "L" are facing down. Bottom hole on "K" is facing away from "L".)
- Align the holes of the two.
- Fasten them together using (2) 9/16" x 6 1/2" Bolts, (4) 3/8" Washers and (2) 9/16" Locking Nuts.

SWING FRAME ASSEMBLY - ROOF ASSEMBLY

STEP
29

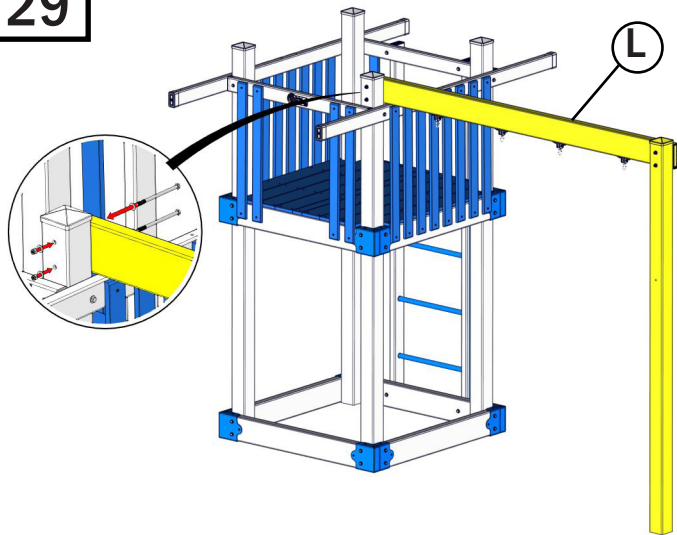

Note: DO NOT OVER-TIGHTEN. Fasten them enough so the parts touch. If the vinyl starts to dent or dimple, you know it is tight enough.

- Set the Swing Frame upright and place the unsupported end of "L" on the inner railing of the tower.
- Align the holes on the end of the 2x6 Swing Beam with the holes on the back of the 4x4 post.
- Fasten them together using the same hardware in the previous step.

STEP
30

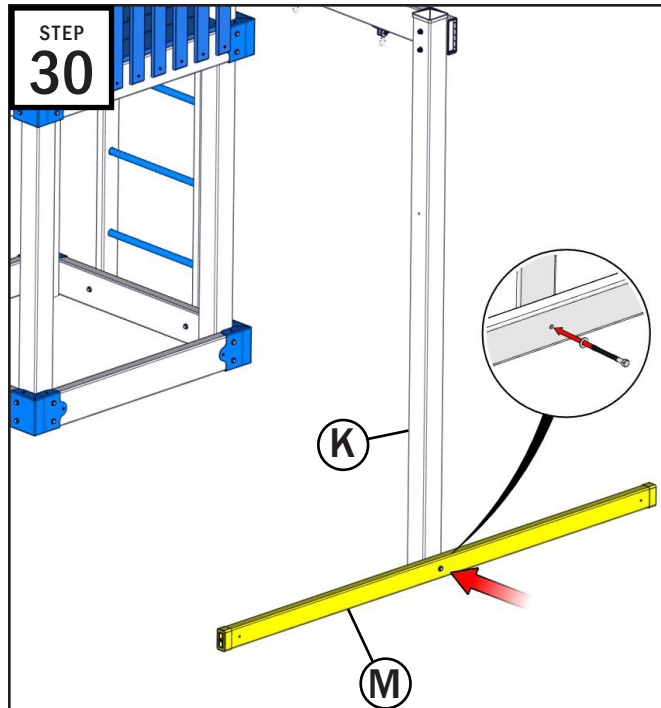

- Place "M" on the ground on the outside of "K".
- Align the center hole on "M" with the hole at the bottom of the "K".
- Fasten together using (1) 9/16" x 4" Lags & 3/8" Washers.

STEP
31

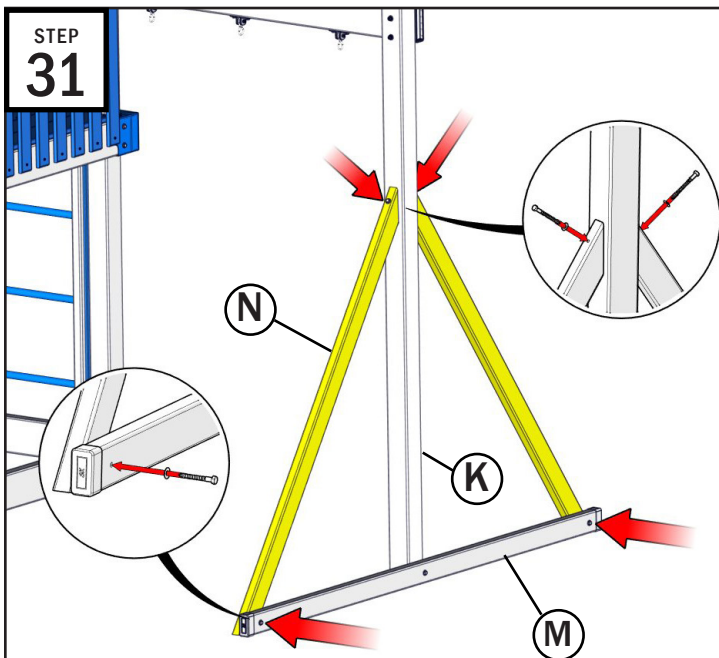

Note: DO NOT OVER-TIGHTEN. Fasten them enough so the parts touch. If the vinyl starts to dent or dimple, you know it is tight enough.

- Place the (2) "N" braces on either side of the "L". Align the pre-drilled holes. Check to make sure the bottom hole is on the correct side.
- Fasten the top of "N" to the 4x4 Post using (2) 9/16" x 4" Lags & 3/8" Washers.
- Fasten the bottom of "N" ends to "M" 2x4 using (2) 9/16" x 3" Lags & Washers.

STEP
32

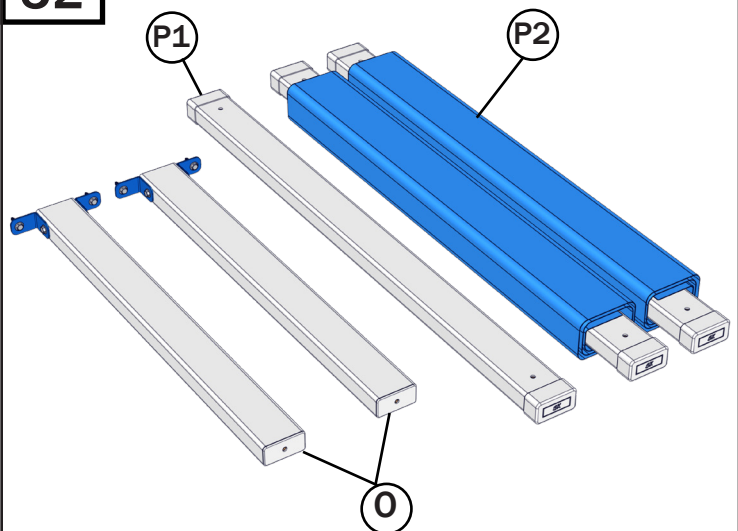

Note: Use caution to not cut the Canvas Roof when cutting the plastic wrapper off.

Locate and prepare the "Roof Bundle" which includes:

- O: (2) 36" 2x4s with L Brackets
- P1: (1) 50 1/2" 2x4
- P2: (1) 108" Canvas Roof with (2) 50 1/2" 2x4s

Also locate the "Roof Hardware" bag.

ROOF ASSEMBLY

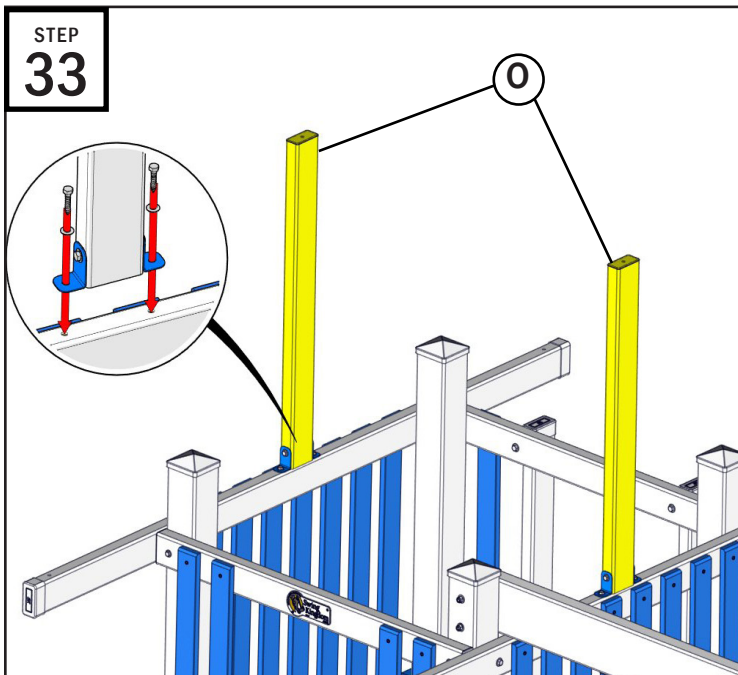

Note: You may want to assemble S & R on the ground, following step 44 if you don't think you will be able to reach the fastening section on step 44.

- Place the (2) "O" on top center of the longer railings.
- Align the holes of the L-brackets with the holes on the railing.
- Fasten them together using (2) 1/2" x 1 1/2" Lag & 5/16" Washers per 2x4.

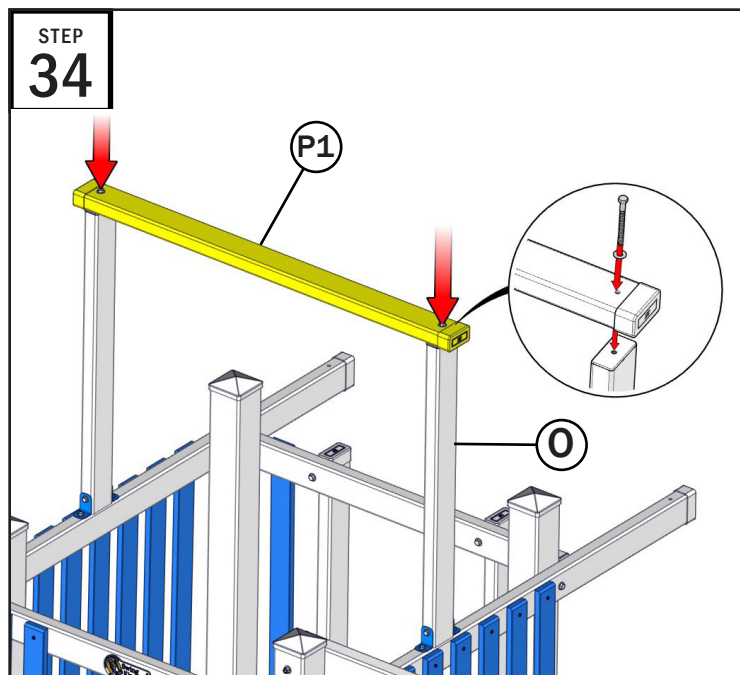

Note: DO NOT OVER-TIGHTEN. Fasten them enough so the parts touch. If the vinyl starts to dent or dimple, you know it is tight enough.

- Place "P1" on top of the 2 "O"s.
- Align the holes on the ends of "P1" with the holes on the top of "O".
- Fasten using (2) 9/16" x 4" Lags & 3/8" Washers.

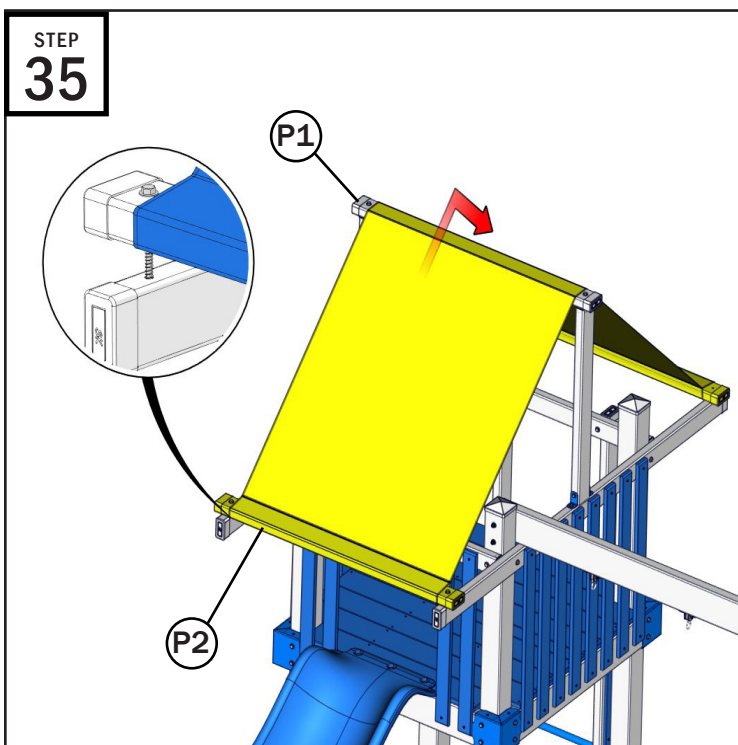

- Place one of the "P2" boards on one of the ends of the long railings.
- Using (2) 9/16" x 4" Lags & Washers, drill into the "P2" holes and drill into the railing end holes enough so that "P2" stays in place like the detail view above.
- Drape the "P2" Canvas over "P1".
- Place the other "P2" board on the other end of the long railings.

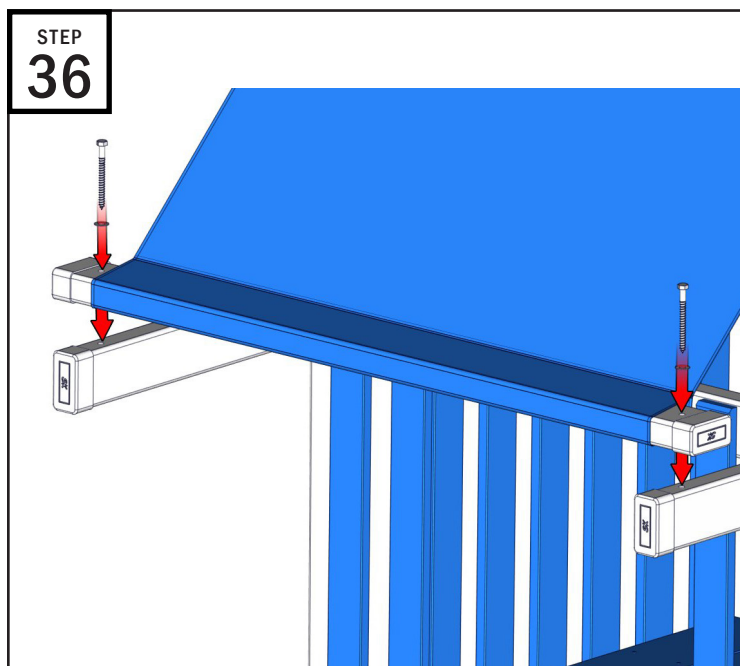

Note: DO NOT OVER-TIGHTEN. Fasten them enough so the parts touch. If the vinyl starts to dent or dimple, you know it is tight enough.

- Align the holes on the other side of the roof.
- Fasten using (2) 9/16" x 4" Lags & 3/8" Washers.
- Finish fastening the 2 Lags used to hold the original "P2" board from the previous step.

Note: This step will help tighten the canvas, so keep an eye on the canvas during this step.

ACCESSORY INSTALL

STEP
37

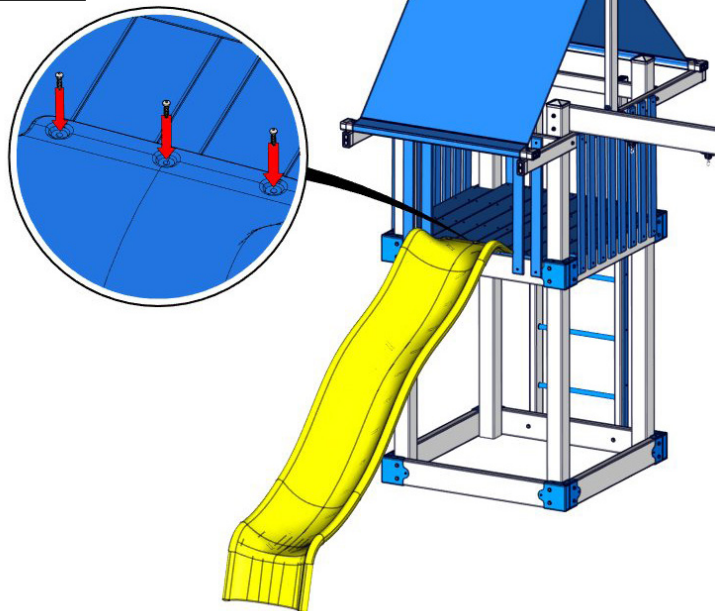

Locate the Waterfall Slide, the (2) Belt Swings and the "Slide Hardware"

- Place the Waterfall Slide center on the front of the tower.
- Position the Waterfall Slide so the holes are directly above the 2x6.
- Fasten the Slide with (3) 1/4" x 1 1/4" Pan Head Screws and (3) 5/16" Washers. (Use the #2 Square Drive Bit to fasten these screws.)

STEP
38

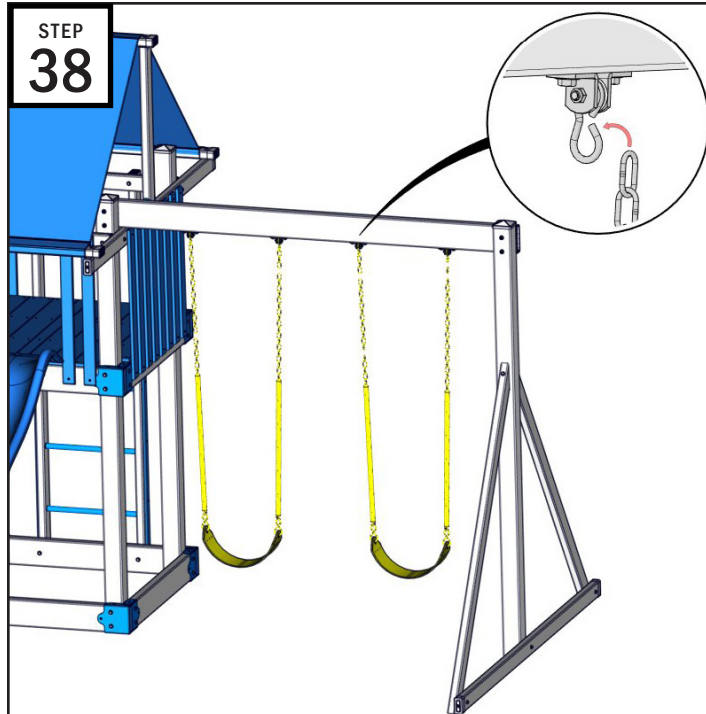

- Hang the Belt Swings from the Swing Hooks on the Swing Beam.
- There will be excess chain to adjust the height of the swing to the appropriate height.

STEP
39

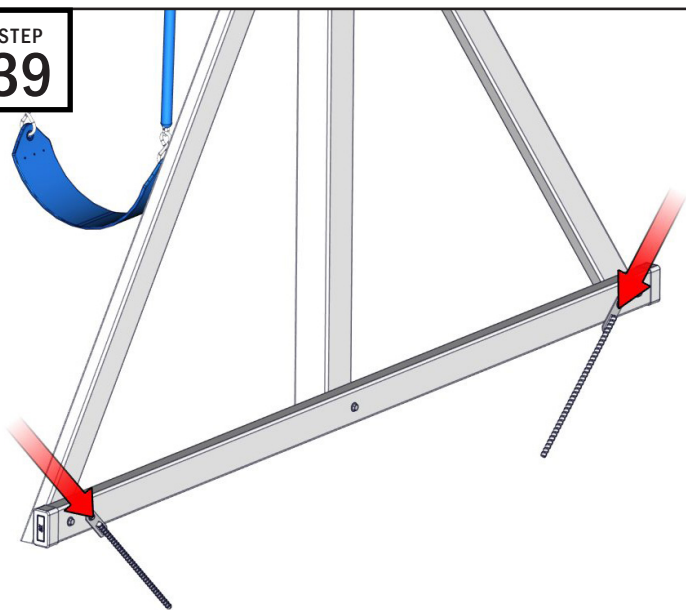

Locate the "Stake Bundle". This bundle will include:

- (2) Stakes
- (2) 1/2" x 1 1/2" Lags
- (2) 5/16" Washers

Using a hammer, drive a Stake into the ground at 45° (perpendicular to the braces) near the ends of the ground 2x4 of the Swing Frame.

STEP
40

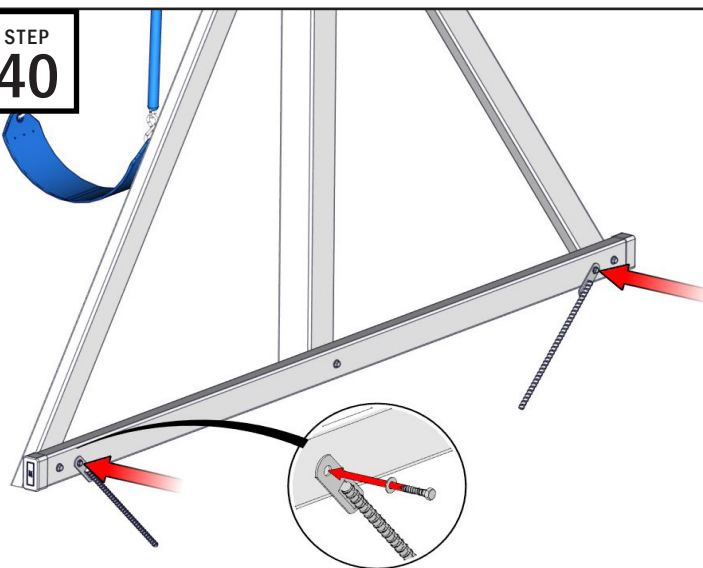

- Fasten the stakes to the Swing Beam using (2) 1/2" x 1 1/2" Lags and (2) 5/16" Washers.

The playset is now complete. Sometimes the vinyl will rub against itself in shipping. If you notice any marks, use windex and a rag or steel wool to clean. Do not overuse steel wool as it can permanently scratch the playset.

COMPLETED PLAYSETS

Moderate 44 shown in Almond & Green



Moderate 44 shown in White & Gray





Swing Kingdom

MIGHTY PLAYSETS. SERIOUS FUN.

Technical Issues?

Contact us at:

Support@swingkingdom.com

717-656-4449